

SET POINT REGULATING UNIT

949 Set point regulating unit

The set point regulating unit is used for underfloor heating systems and installed directly on the manifold in the box, thanks to its small overall dimensions.

The minimum depth of the metal box required for the installation of the regulation unit is 90 mm.

The regulation consists of lowering and keeping constant the temperature of the medium fluid using a 3-way mixing valve equipped with an adjustable thermostatic head with a built-in sensor.

A circulation pump (available on request) allows fluid to circulate in the pipes, while a safety thermostat limits the maximum temperature.

SET POINT REGULATING UNIT



949CPF

With low energy consumption pump.

MEASURE	PRESSURE	CODE	PACKING
1"	6bar/87psi	9490100200CPF	1/2

949SPF

Without low energy consumption pump.

MEASURE	PRESSURE	CODE	PACKING
1"	6bar/87psi	9490100200SPF	1/4

TECHNICAL SPECIFICATIONS

Consisting of:

- 3-way mixing valve
- Thermostatic head with built-in sensor
- Safety cutoff (factory set at 55°C)
- Thermometer (scale 0°-80°C) fitted to the flow and return pipes
- Low energy consumption pump (on demand)

Technical specifications:

- Medium fluid: water, glycolate solutions max. 30%
- Temperature setting: 20°C – 55°C
- Maximum working pressure: 6 bar
- Body and fittings: nickel-plated brass
- Available size: 1"
- ISO 228 threads (equivalent to DIN EN ISO 228 and BS EN ISO 228)

For a right installation of the set point regulating unit we suggest to use one of the following mounting brackets:

- Art. 498STK with centres distance mm 200 and offset mm 12.
- Art. 949ST.

SET POINT REGULATING UNIT

OVERALL DIMENSIONS

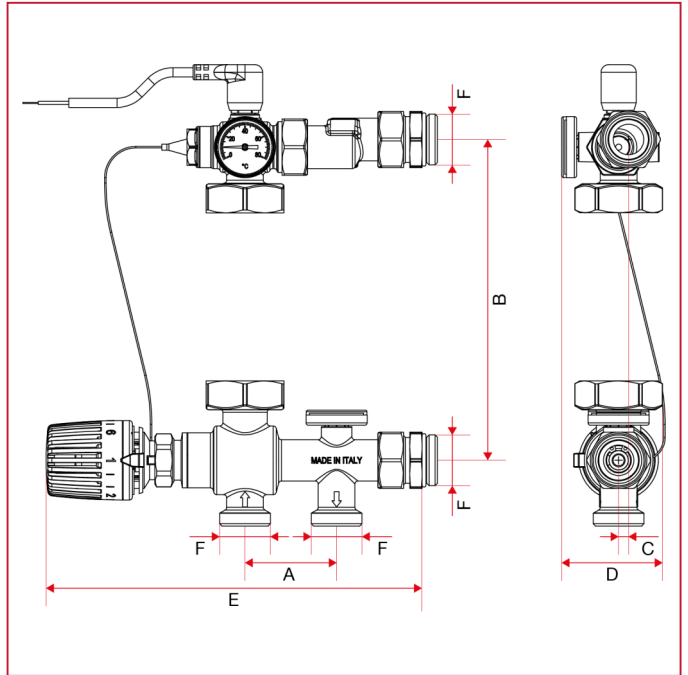
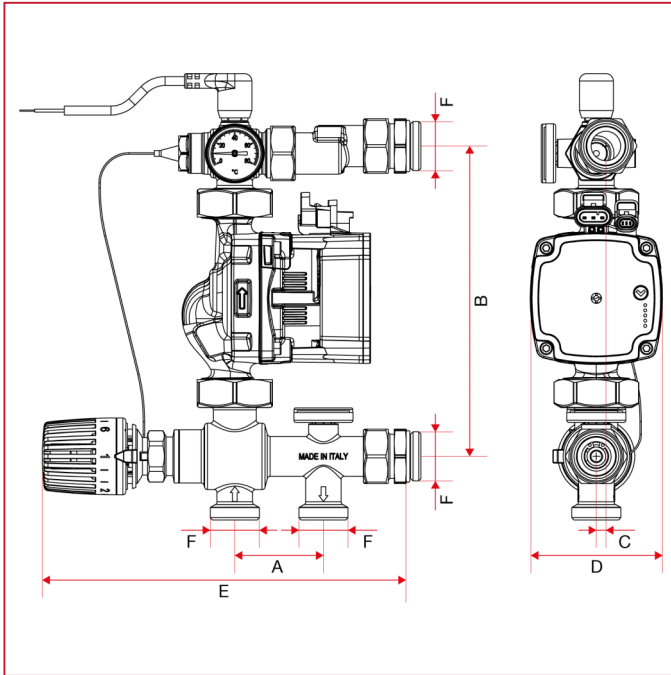

949CPF

	1"
A	60
B	200 - 210
C	6,5
D	90
E	250
F	1" M ISO228
Kg/cm ² bar	6
LBS - psi	87

949SPF

	1"
A	60
B	200-210
C	6,5
D	66
E	250
F	1" M ISO228
Kg/cm ² bar	6
LBS - psi	87

SET POINT REGULATING UNIT

MATERIALS

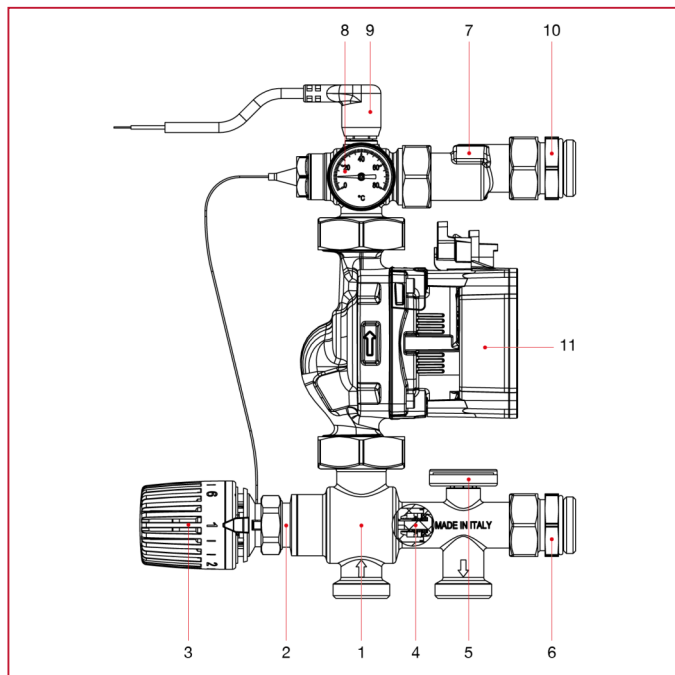

POS.	DESCRIPTION	N.	MATERIAL
1	Mixing valve	1	Nickel-plated brass
2	Bonnet M30 x 1,5	1	Brass
3	Thermostatic control	1	ABS
4	Check Valve	1	POM
5	Return circuit temperature gauge	1	ABS
6	Return circuit connection	1	Brass
7	Offset supply manifold	1	Nickel-plated brass
8	Supply circuit temperature gauge	1	ABS
9	Safety thermostat	1	Aluminium
10	Supply circuit connection	1	Brass
11	High efficiency circulator	1	Cast iron

SET POINT REGULATING UNIT

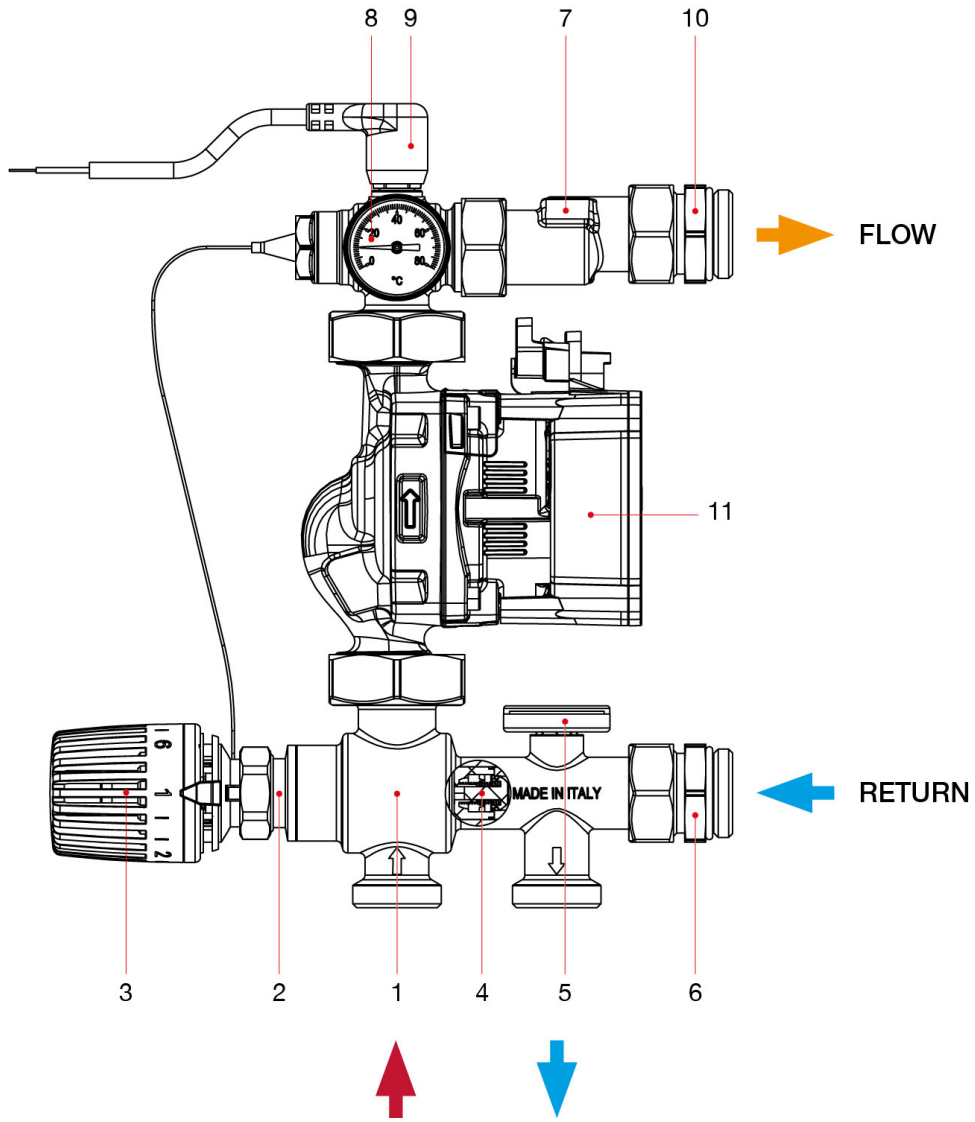

Regulation of the flow temperature:

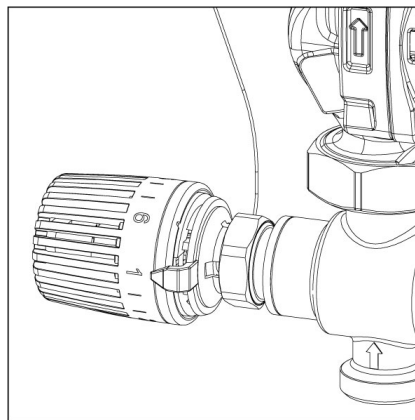

1	2	3	4	5	6
20°C	30°C	40°C	50°C	60°C	70°C

SET POINT REGULATING UNIT

The thermostatic head adjusts the flow water temperature in the low temperature circuit. To set the temperature, simply rotate the head to the desired value, matching the adjustment scale with the thermostatic head indicator.

Once the temperature has been set, check with the thermometer on the supply circuit that the temperature corresponds to the desired value.

Important: The safety thermostat is factory-set at 55 °C in normally closed condition.

Circulator characteristics:

The circulator can be set to operate in proportional pressure (PP), constant pressure (CP) or constant curve (CC) mode. For underfloor heating circuits, the recommended mode is constant pressure (CP), so that the available head is kept constant regardless of the heat demand of the system. For each mode, 3 different speed levels are available: lower (1), intermediate (2) and higher (3). Using the AUTOADAPT (AA) function, the circulator adapts its performance automatically based on the size of the system and the varying conditions over time.

To set up the product, use the button on the control panel. Each time the button is pressed, the pump setting changes. The LEDs will indicate the selected control mode, according to the following diagram:

Mode	LED 1	LED 2	LED 3	LED 4	LED 5
PP AA	●				
CP AA		●			
PP 1	●		●		
PP 2	●		●	●	
PP 3	●		●	●	●
CP 1		●	●		
CP 2		●	●	●	
CP 3		●	●	●	●
CC 1			●		
CC 2			●	●	
CC 3			●	●	●

Circulator control logic:

The circulator logic allows you to control the switching on and off of the circulator installed on the regulation unit and the closing and opening of a clean contact for starting the boiler, by means of two analogue inputs: TERM AMB (ambient thermostat) and TERM SIC (safety thermostat).

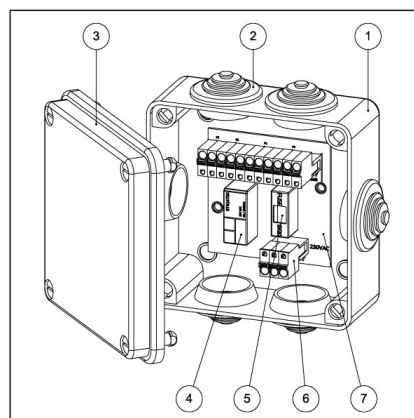

1. Plastic box
2. Rubber clamp
3. Cover
4. Relay
5. Fuse
6. Quick fit connector
7. PBC

SET POINT REGULATING UNIT

If necessary, the fuse can be replaced with one of the same characteristics (2 A, 250 V, Ø5 x 20 mm).

The circulator logic is built according to the rule of art and in compliance with the directives and laws of the member states of the European Community.

- Electromagnetic Compatibility Standard 89/336/EEC.
- Product electrical safety regulation 2006/95/EEC.

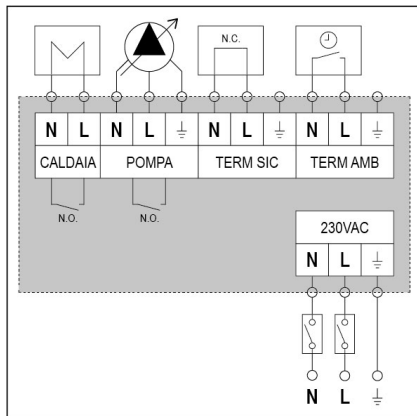

Operating logic (0 = contact open, 1 = contact closed):

TERM AMB	TERM SIC	PUMP	BOILER
0	0	OFF	OFF
0	1	OFF	OFF
1	0	OFF	OFF
1	1	ON	ON

230VAC	Input	230 V AC power supply
TERM AMB	Input	Clean contact for consent from room thermostat or from auxiliary contacts of the electrothermal actuators.
TERM SIC	Input	Clean contact for consent from safety thermostat
POMPA	Output	Circulator power supply
CALDAIA	Output	Normally open clean contact for boiler consent

CIRCULATOR GRAPH

SET POINT REGULATING UNIT

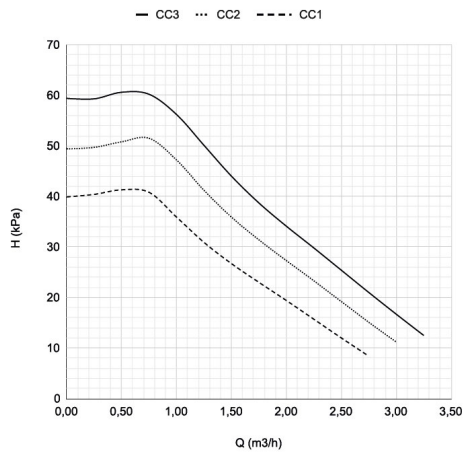

CC (constant speed): the circulator runs on a constant speed curve, which means that it runs at a constant speed or power. The working point of the circulator moves up or down the selected constant curve, according to the heat demand in the system.

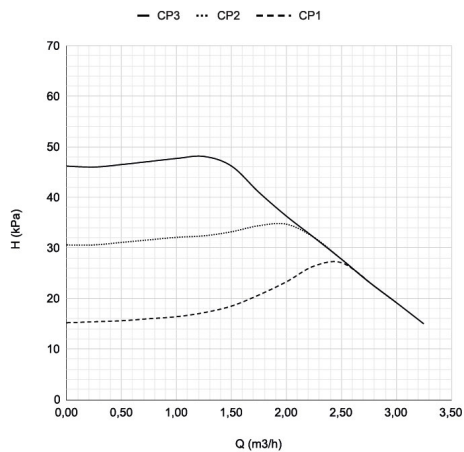

CP (constant pressure): the head (pressure) is kept constant, regardless of the heat demand. The duty point of the circulator will move towards the outside or inside of the selected constant pressure curve, according to the heat demand in the system.

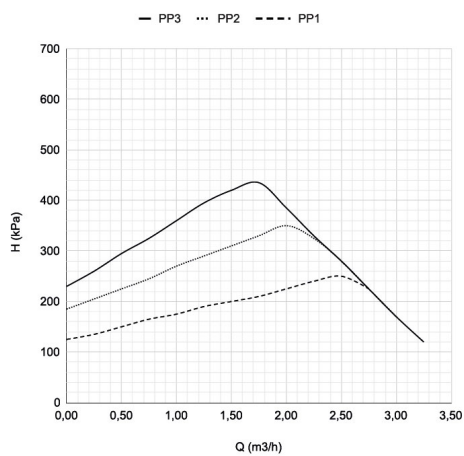

PP (proportional pressure): the head (pressure) decreases as the heat demand decreases and increases as the heat demand increases. The working point of the circulator will move up or down by the selected proportional pressure curve, according to the heat request in the system.

REGULATING UNIT PRESSURE DROP

SET POINT REGULATING UNIT

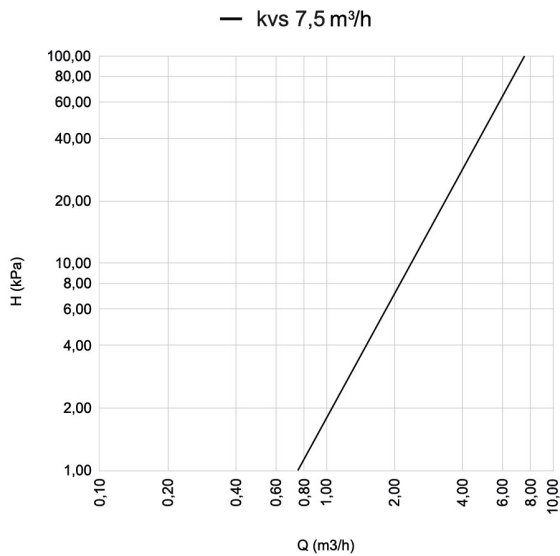

POSITIONING THE REGULATING UNIT INTO THE METAL BOX

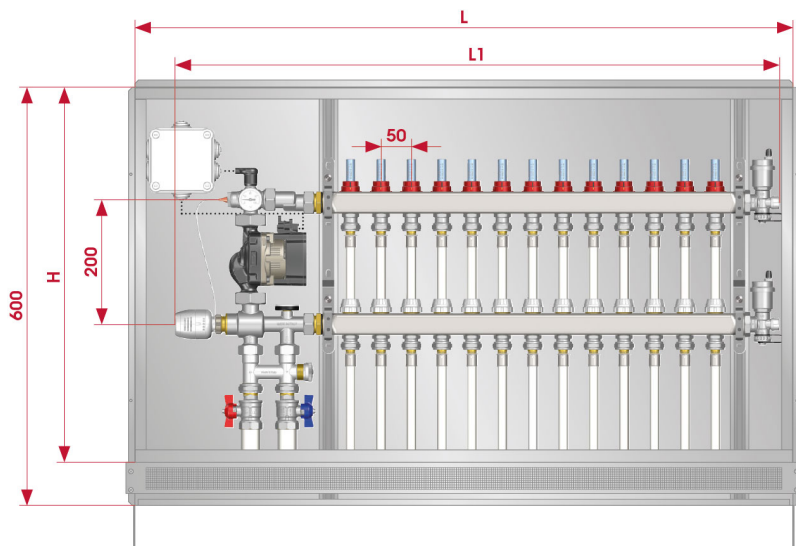

CODE	498.600.500	498.700.500	498.800.500	498.900.500	498.1000.500	498.1100.500
LxH (mm)	600x500	700x500	800x500	900x500	1000x500	1100x500
N. ways	2-3	4-5	6-7	8-9	10-11	12-13
MANIFOLD	1"					
L1	495	595	695	795	895	995

CONSTRUCTION

The regulating unit is housed in a galvanised steel box (depth 90 mm), which makes it ideal for installation in thin walls. To protect the contents of the enclosure and facilitate the necessary masonry work, it is fitted with a galvanised steel cover, which mounts to the front of the enclosure with four screws. The cover has a 1 cm rim, which acts as a plastering guide. Both the front and back of the enclosure are fitted with mesh to prevent the plaster retracting and cracking. Once the enclosure has been installed and plastered over, remove the cover and fit the door. These are made of galvanised steel with a white (RAL9010) coating and protective film which is removed at the end of the installation process. The base of the enclosure is adjustable vertically by 100 mm, while its door can be adjusted inwards or outwards by 50 mm. The roof of the enclosure has holes for routing the electrical cables.

SET POINT REGULATING UNIT

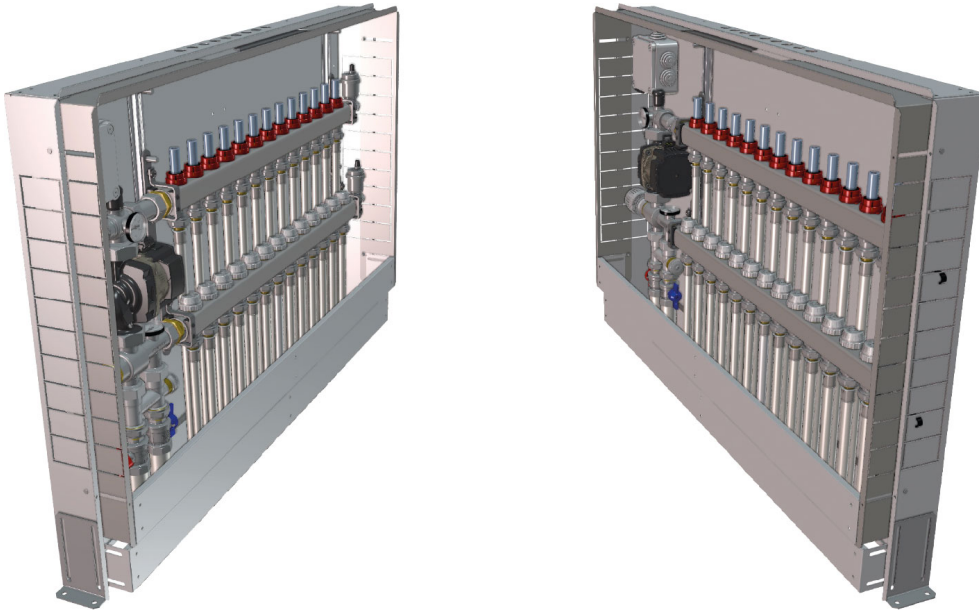

The 3-way mixing valve has 20 mm inside diameter. This large diameter means that the medium can be heated up to the desired temperature quicker than with units with smaller diameter ports. The result is that the circulator pump runs for less time throughout the day, which considerably reduces its power consumption. An additional saving is represented by the use of variable speed circulator pumps compliant with Directive ErP 2015 (starting from January 1st 2013), which considerably reduces power consumption and promote the new concept of eco-design.

INSTALLATION OF REGULATING UNIT

1. The control unit is supplied with the connection of the main pipes down, with the outlet on the left and the return on the right.
2. Using the swivel fittings, connect the unit to the secondary pipes or distributor manifolds, paying attention to connecting the supply circuit to the outlet at the top and the return circuit on the bottom one.
3. Connect the primary circuit bypass (optional) and the ball valves (optional), paying attention to connecting the supply circuit to the left and the return circuit to the right.
4. Connect the main pipes.

PRIMARY CIRCUIT BY-PASS

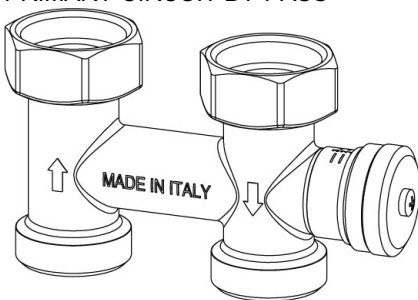

The by-pass for the primary circuit (optional) allows the hydraulic separation between the primary and secondary circuit. This hydraulic separation optimizes the operation of the secondary circuit and prevents changes in the flow rate of the primary from affecting the secondary circuit. The flow rate that passes through the respective circuits depends exclusively on the flow rate characteristics of the pumps, avoiding the mutual influence due to their coupling in series.

An adjustable differential valve is placed on the by-pass, whose intervention value can be changed using the appropriate knob. If the secondary circuit is closed, the differential valve opens to allow the water to return to the boiler.

SET POINT REGULATING UNIT

INSTRUCTIONS

The circulator logic allows you to control the switching on and off of the circulator installed on the regulation unit and the closing and opening of a clean contact for starting the boiler, by means of two analogue inputs: TERM AMB (ambient thermostat) and TERM SIC (safety thermostat).

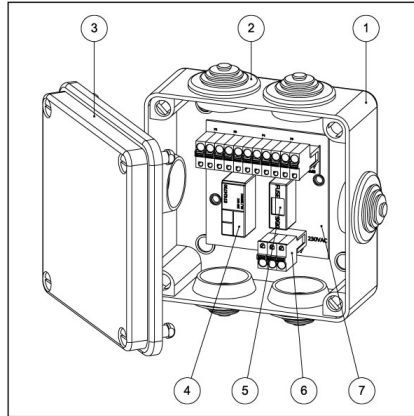

1. Plastic box
2. Rubber clamp
3. Cover
4. Relay
5. Fuse
6. Quick fit connector
7. PBC

If necessary, the fuse can be replaced with one of the same characteristics (2 A, 250 V, Ø5 x 20 mm).

The circulator logic is built according to the rule of art and in compliance with the directives and laws of the member states of the European Community.

- Electromagnetic Compatibility Standard 89/336/EEC.
- Product electrical safety regulation 2006/95/EEC.

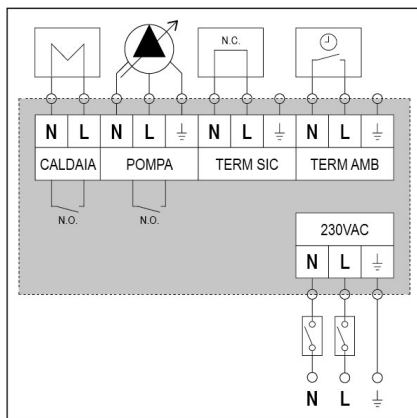

Operating logic (0 = contact open, 1 = contact closed):

TERM AMB	TERM SIC	PUMP	BOILER
0	0	OFF	OFF
0	1	OFF	OFF
1	0	OFF	OFF
1	1	ON	ON

SET POINT REGULATING UNIT

230VAC	Input	230 V AC power supply
TERM AMB	Input	Clean contact for consent from room thermostat or from auxiliary contacts of the electrothermal actuators.
TERM SIC	Input	Clean contact for consent from safety thermostat
POMPA	Output	Circulator power supply
CALDAIA	Output	Normally open clean contact for boiler consent

SET POINT REGULATING UNIT

MATERIALS

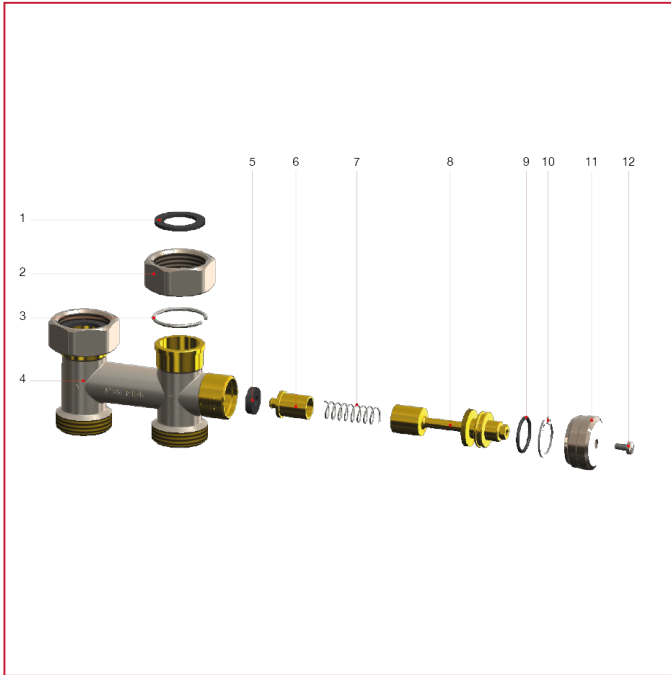

POS.	DESCRIPTION	N.	MATERIAL
1	GP EPDM 30 X 20 X 2	2	EPDM
2	NICKEL-PLATED NUT 1" H=17MM	2	CW617N
3	ELASTIC RING 28,5 X 2	2	AISI 304
4	BY-PASS BODY 1"	1	CW617N
5	GP EPDM 16 X 06 X 04	1	EPDM
6	BY-PASS SHUTTER	1	CW614N
7	SPRING 10 X 4 X 0.8 L=33	1	AISI 304
8	BY-PASS STEM M22X1	1	CW614N
9	OR EPDM 18.00 X 02.00	1	EPDM
10	ELASTIC RING FOR D. 23 HOLE	1	AISI 304
11	By-pass handle	1	CW614N
12	SCREW M4 X 7	1	STEEL

SET POINT REGULATING UNIT

INSTRUCTIONS

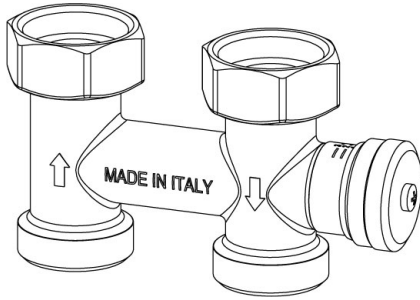

The by-pass for the primary circuit (optional) allows the hydraulic separation between the primary and secondary circuit. This hydraulic separation optimizes the operation of the secondary circuit and prevents changes in the flow rate of the primary from affecting the secondary circuit. The flow rate that passes through the respective circuits depends exclusively on the flow rate characteristics of the pumps, avoiding the mutual influence due to their coupling in series.

An adjustable differential valve is placed on the by-pass, whose intervention value can be changed using the appropriate knob. If the secondary circuit is closed, the differential valve opens to allow the water to return to the boiler.

Setting	Opening pressure
3	30 kPa
2	20 kPa
1	10 kPa
Completely open	5 kPa